

Wigan LEA Numeracy Centre

Year 5

Block 3 Assessment

5

Section A – Read and Respond

Name:

Date:

<b>Key Objectives Assessed</b>	<b>Question</b>
Ordering positive and negative integers	1
Relate fractions to their equivalent decimals	6
Calculate differences mentally	11, 12
Recognise parallel and perpendicular lines	8
Calculate the area of a rectangle	10
Know by heart multiplication up to 10 x 10	4
<b>Other Objectives Assessed</b>	
Derive doubles of multiples of 100 and 100 up to 10,000	2
Relate fractions to division	3, 5
Find simple percentages of small whole number quantities	7
Use a protractor to measure angles to the nearest 5°	9
Calculate a temperature fall across 0°C	1
Recognise and extend number sequences from any number in steps of constant size	13

<u>Correct Responses</u>

<u>Mark</u>

<b>Overall level for Block 3 A &amp; B</b>

1.

Look at the table showing temperatures of British towns in February.

Town	Temperature
Aberdeen	-5°C
Glasgow	-6°C
Kendal	-3°C
London	4°C
Manchester	2°C
Wigan	-1°C

- a. Which **town** had the highest temperature? \_\_\_\_\_
- b. Which **town** had the lowest temperature? \_\_\_\_\_
- c. What is the difference in temperature between London and Glasgow? \_\_\_\_\_
- d. Which **two towns** have a difference of 4°C ?  
\_\_\_\_\_ and \_\_\_\_\_

(3)

2.

Complete these doubling and halving sentences

a.  $370 \times 2 = \square$

b.  $2 \times \square = 520$

c.  $2 \times 3200 = \square$

d.  $2 \times \square = 6800$

e.  $2 \times 4900 = \square$

(2)

3.

Complete these number sentences. Write your answer as a fraction.

e.g.  $21 \div 10 = 2\frac{1}{10}$

a.  $21 \div 4 = \square$

b.  $8 \div 3 = \square$

c.  $38 \div 9 = \square$

d.  $27 \div \square = 6\frac{3}{4}$

e.  $\square \div 7 = 5\frac{1}{7}$

(3)

4.

Complete this multiplication table

X	4	6	7	8	9
2	8	12	14	16	18
6					
7					
8					
9					

(3)

5.

Complete this fraction grid.

Start Number	24	48	72	96	144
To find $\frac{1}{3}$ (divide by 3)	8		24		48
To find $\frac{1}{6}$ (half of $\frac{1}{3}$ )	4	8			

(3)

6.

The table shows decimal numbers and equivalent fractions.  
Complete the table below

Decimals	Equivalent Fractions
0.7	
0.03	
	$\frac{3}{4}$
	$\frac{1}{100}$
1.48	

(2)

7.

a. 50% of £7 =

b. 25% of £10 =



c. 10% of £30 =

d. 10% of £4 =

e. 75% of £20 =

(2)

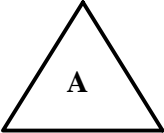
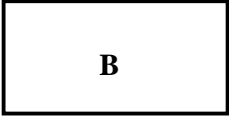
8.

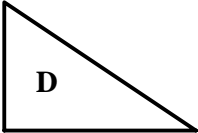
Which shape has ONE pair of PARRALLEL sides? .....

Which shape has TWO pairs of PARRALLEL sides? .....

Which shape contains only ONE right angle? .....

(2)

9.

Use an angle measurer to measure these angles

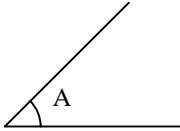

°

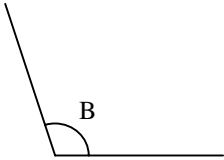

°

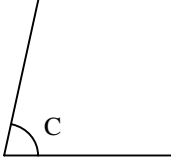

°

(2)

10.

Calculate the area of these shapes.

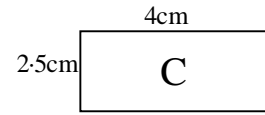
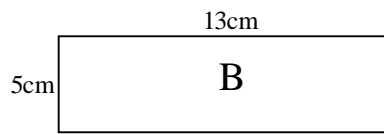
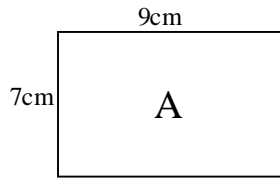

$$A = \boxed{\phantom{000}} \text{ cm}^2$$

$$B = \boxed{\phantom{000}} \text{ cm}^2$$

$$C = \boxed{\phantom{000}} \text{ cm}^2$$

(2)

11.

Calculate the following differences

$$a. 43 - 36 = \boxed{\phantom{00}}$$

$$b. 106 - 97 = \boxed{\phantom{00}}$$

$$c. 707 - 689 = \boxed{\phantom{00}}$$

$$d. 1002 - 994 = \boxed{\phantom{00}}$$

$$e. 3000 - 1995 = \boxed{\phantom{00}}$$

(2)

12.

$$a. 1.6 - 1.5 = \boxed{\phantom{00}}$$

$$b. 9.8 - 7.4 = \boxed{\phantom{00}}$$

$$c. 470 - 380 = \boxed{\phantom{00}}$$

$$d. 9.2 - 8.6 = \boxed{\phantom{00}}$$

$$e. 810 - 380 = \boxed{\phantom{00}}$$

(2)

13.

Complete these number sequences

$$a) 250, 275, 300, \boxed{\phantom{000}}, 350$$

$$b) 975, 950, 925, 900, \boxed{\phantom{000}}$$

$$c) 10, 18, 26, \boxed{\phantom{000}}, 42$$

$$d) 2.3, 2.6, 2.9, \boxed{\phantom{000}}, 3.5$$

$$e) 87, 78, 69, 60, \boxed{\phantom{000}}$$

(2)

Wigan LEA Numeracy Centre  
Year 5  
Block 3 Assessment

5

Section B – Problem Solving and Calculator Activities

Name:

Date:

**Calculators may be used throughout this paper**

<b>Objectives Assessed: Solve a Problem by -</b>	<b>Question</b>
Interpreting and representing data in a line graph	4, 7
Using all four operations to solve word problems involving money	1, 2
Use all four operations to solve word problems involving time	9, 10, 11
Applying multiplication (TU x TU)	13, 14, 15, 16
Applying multiplication (HTU x U)	1, 2, 3
Using all four operations to solve word problems	3
Interpreting results from a table	5
Interpreting results from a Venn Diagram	6
Calculating angles on a straight line	8
Using simple ratio and proportion contexts	12
Using a calculator effectively	17, 18, 19

Correct responses

Mark

1.	<p>In a shop there are 7 jars of sweets. Each jar contains 254 sweets. How many sweets are there all together?</p> <p>Show your working out</p> <div data-bbox="285 380 1317 737" style="border: 1px solid black; padding: 10px;"><div data-bbox="1078 638 1304 716" style="border: 1px solid black; width: 139px; height: 37px; margin-left: auto;"></div></div>
----	---

(2)

2.	<p>Amanda earns £325 per week. How much does she earn in 6 weeks?</p> <p>Show your working out</p> <div data-bbox="285 911 1317 1268" style="border: 1px solid black; padding: 10px;"><div data-bbox="1078 1173 1304 1251" style="border: 1px solid black; width: 139px; height: 37px; margin-left: auto; text-align: center;">£</div></div>
----	--

(2)

3.	<p>Sue reads 9 pages of a book. On each page there are 412 words. How many words does she read altogether?</p> <p>Show your working out</p> <div data-bbox="285 1484 1317 1818" style="border: 1px solid black; padding: 10px;"><div data-bbox="1078 1722 1304 1799" style="border: 1px solid black; width: 139px; height: 37px; margin-left: auto;"></div></div>
----	---

(2)

4.

Nicola boils some water. She checks the temperature of the water as it cools. Nicola plotted the results on a graph.

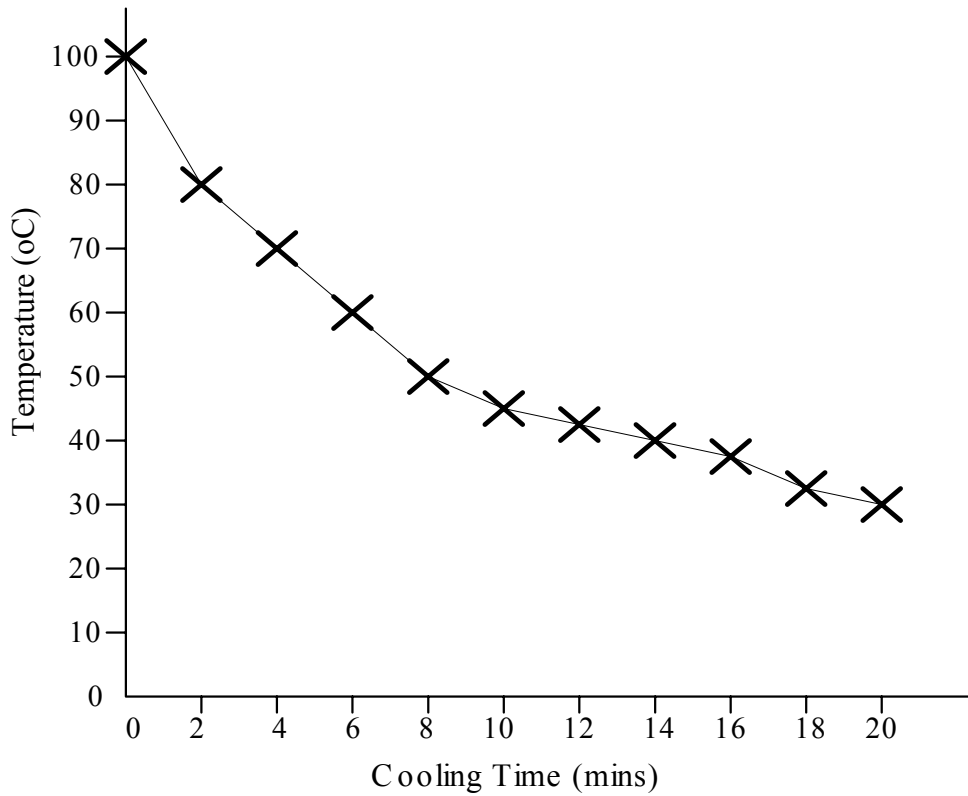

a) What was the temperature of the water after 8 minutes?

 °C

b) How long did it take for the temperature to fall from 40°C to 30°C?

 °C

c) Tick the time period when the temperature of the water cooled most quickly

0 – 4  
minutes

4 – 8  
minutes

8 – 12  
minutes

12 – 16  
minutes

16 – 20  
minutes

 (2)



5.

Sally collects data about her friends. Look at the results in the table.

Name of friend	What is your eye colour?	What is your height?	What is your mass?	Do you have a pet dog?	How many music CD's do you have?
Ann	Blue	1.36m	40kg	X	8
Babs	Brown	1.38m	43kg	√	10
Carol	Brown	1.41m	43kg	√	14
Dave	Green	1.56m	50kg	X	3
Eric	Brown	1.29m	37kg	X	5

a) How much taller is Carol than Eric?

b) Who has brown eyes but does not have a dog?

c) What is the mode of the mass of her friends?

d) How many CD's do her friends have altogether?

(2)

6.

Put these numbers in the Venn Diagram

49      33      81

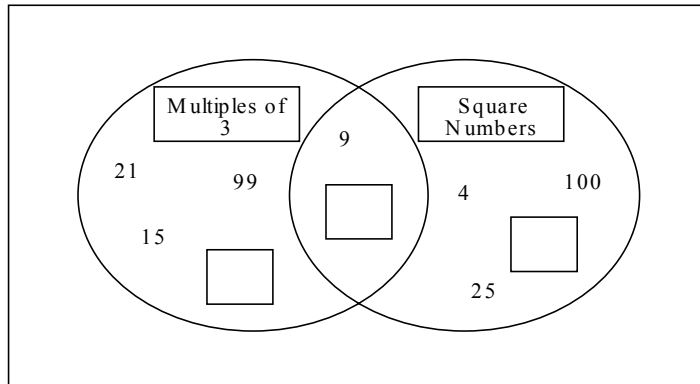

(1)

7.

This bar line chart shows how many times each number was thrown when a dice was rolled 50 times.

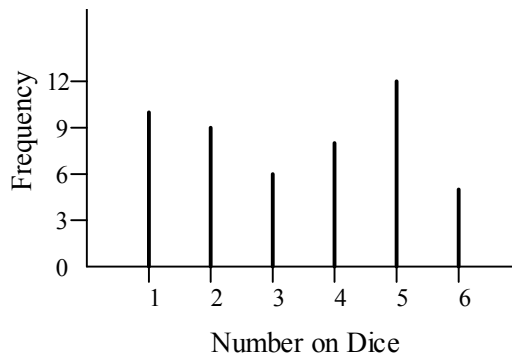

a) How many times was number 1 thrown?

b) Which number was thrown 8 times?

c) The next time you roll the dice are you more likely to roll a 5 than a 6?  yes  no

Give a reason for your answer .....

.....  
.....

(1)

(2)

8.

Calculate these angles. All the angles are on a straight line.

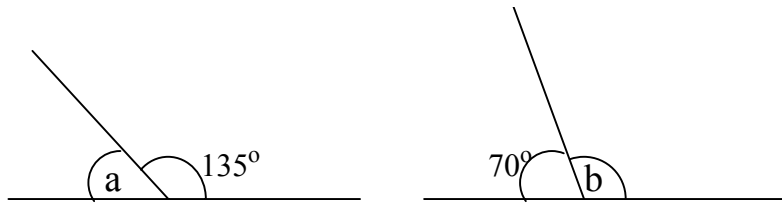

A = °

B = °



C = °

(2)

9.

A walk began at 09:45 and finished at 14:35. How long did the walk last?

minutes

(2)

10.

The sun sets at 22:00 and rises again at 05:00. How many hours of darkness were there that night?

hours

(1)

11.

Four children ran in a relay race. Here are their times for each lap.

Albert	94.5 seconds
Beryl	90.2 seconds
Carl	83.1 seconds
Dan	85.4 seconds

- a) What is their total time for four laps? ..... seconds
- b) Who ran the fastest lap? .....
- c) How much quicker was Beryl than Albert? .....

(2)

12. On school trips there has to be **one** adult for every **ten** children.

a) If 70 children go to Blackpool, how many adults need to go with them?

b) If 12 adults can go on the school trip to the zoo, how many children can go?

(1)

(1)

13. **16 teams** played in the World Cup Finals. Each team had **23 players** to choose from. How many players were there altogether?

Show your working out

(2)

14. Gerry picked **18 baskets** of strawberries. Each basket contained **36 strawberries**. How many strawberries had he picked altogether?

Show your working out

(2)

15.

There are **36 children** in a class. The teacher bought every child a chocolate bar costing **32p**. How much money did the teacher spend?

Show your working out

£

(2)

16.

Tommy buys one music CD **every week**. Each CD costs **£16**. How much does Tommy spend in **one year**?

Show your working out

£

(2)

17.

### Calculator Activities

Use a calculator to help you complete these number sentences.  
Put the operation signs + - x ÷ in the boxes.

a)  $43 \square 63 = 2709$

b)  $1792 \square 56 = 32$

c)  $5487 \square 5232 = 255$

d)  $2341 \square 23 = 2364$

e)  $10 \square 17 = 85 \square 2$

f)  $10 \square 24 = 680 \square 20$

(3)

Calculator Activities

18.

Find the numbers to complete these sentences.

a)  $987 \div \square = 329$

b)  $25 \times \square = 1400$

c)  $222 \div 74 = \square$

d)  $56.8 \times \square = 284$

(2)

19.

How many seconds are there in the month of June?

Show your working out

(3)

# Y5 Block 3 Assessment Section A

## Answers and Suggested Mark

### Scheme

[www.11plusguide.com](http://www.11plusguide.com)

Question	N. C. Level	Answer	Marks	Total Marks																																				
1	5C	a) London      c) 10°C b) Glasgow    d) Aberdeen & Wigan	All correct – 3 marks 3 correct – 1 mark	3																																				
2	4C	a) 740            d) 3400 b) 260            e) 9800 c) 6400	All correct – 2 marks 3 or 4 correct – 1 mark	2																																				
3	4A	a) $5\frac{1}{4}$ d) 4 b) $2\frac{2}{3}$ e) 36 c) $4\frac{2}{9}$	All correct – 3 marks 3 or 4 correct – 2 marks 2 correct – 1 mark	3																																				
4	4C	<table border="1" style="margin-left: auto; margin-right: auto; border-collapse: collapse; text-align: center;"> <tr><td>X</td><td>4</td><td>6</td><td>7</td><td>8</td><td>9</td></tr> <tr><td>2</td><td>8</td><td>12</td><td>14</td><td>16</td><td>18</td></tr> <tr><td>6</td><td>24</td><td>36</td><td>42</td><td>48</td><td>54</td></tr> <tr><td>7</td><td>28</td><td>42</td><td>49</td><td>56</td><td>63</td></tr> <tr><td>8</td><td>32</td><td>48</td><td>56</td><td>64</td><td>72</td></tr> <tr><td>9</td><td>36</td><td>54</td><td>63</td><td>72</td><td>81</td></tr> </table>	X	4	6	7	8	9	2	8	12	14	16	18	6	24	36	42	48	54	7	28	42	49	56	63	8	32	48	56	64	72	9	36	54	63	72	81	All correct – 3 marks 6 - 10 correct - 2 marks 0 – 5 correct – 0 marks	3
X	4	6	7	8	9																																			
2	8	12	14	16	18																																			
6	24	36	42	48	54																																			
7	28	42	49	56	63																																			
8	32	48	56	64	72																																			
9	36	54	63	72	81																																			
5	4B	<table border="1" style="margin-left: auto; margin-right: auto; border-collapse: collapse; text-align: center;"> <tr><td>Start Number</td><td>24</td><td>48</td><td>72</td><td>96</td><td>144</td></tr> <tr><td>To find <math>\frac{1}{3}</math></td><td>8</td><td>16</td><td>24</td><td>32</td><td>48</td></tr> <tr><td>To find <math>\frac{1}{6}</math></td><td>4</td><td>8</td><td>12</td><td>16</td><td>24</td></tr> </table>	Start Number	24	48	72	96	144	To find $\frac{1}{3}$	8	16	24	32	48	To find $\frac{1}{6}$	4	8	12	16	24	All correct – 3 marks 3 or 4 correct – 2 marks 0 – 2 correct – 0 marks	3																		
Start Number	24	48	72	96	144																																			
To find $\frac{1}{3}$	8	16	24	32	48																																			
To find $\frac{1}{6}$	4	8	12	16	24																																			
6	4B	$\frac{7}{10}, \frac{3}{100}, 0.75, 0.01, 1\frac{48}{100}$ or $1\frac{24}{50}$ or $1\frac{12}{25}$	All correct – 2 marks 3 - 4 correct – 1 mark	2																																				
7	5C	a) £3.50            d) 40p b) £2.50            e) £15.00 c) £3.00	All correct - 2 marks 3 – 4 correct – 1 mark	2																																				
8	4C	C, B, D	All correct – 2 marks 2 correct - 1 mark	2																																				
9	4B	a) 45°    b) 107°    c) 78° (allow 1 degree either way)	All correct – 2 marks 2 correct – 1 mark	2																																				
10	4B	a) 63cm <sup>2</sup> b) 65cm <sup>2</sup> c) 10cm <sup>2</sup>	All correct – 2 marks 2 correct – 1 mark	2																																				
11	4C	a) 7                    d) 8 b) 9                    e) 1005 c) 18	All correct – 2 marks 3 – 4 correct – 1 mark	2																																				
12	4B	a) 0.1                d) 0.6 b) 2.4                e) 430 c) 90	All correct – 2 marks 3 - 4 correct – 1 mark	2																																				
13	4B	a) 325                d) 3.2 b) 875                e) 51 c) 34	All correct – 2 marks 3 – 4 correct – 1 mark	2																																				

<p style="margin: 0;"><u>Total</u></p> <p style="margin: 0; font-size: 1.2em;">30</p>
---

## Y5 Block 3 Assessment Section B

Question	N. C. Level	Answer	Marks	Total Marks
1	4B	1778	Correct answer – 2 marks Correct method – 1 mark	2
2	4B	1950	Correct answer – 2 marks Correct method – 1 mark	2
3	4B	3708	Correct answer – 2 marks Correct method – 1 mark	2
4	4A	a) 50°C    b) 6 mins    c) 0 – 4 mins	All correct – 2 marks 2 correct - 1 mark	2
5	4B	a) 12cm    b) Eric    c) 43kg    d) 40	All correct – 2 marks 3 correct – 1 mark	2
6	4A	a) 49 – square number b) 33 – multiple of 3 c) 81 both	All correct – 1 mark	1
7a, b	4A	a) 10    b) 4	Both correct – 1 mark	1
7c	4A	No – any appropriate reason e.g. 1 in 6 chance of rolling 5 or 6	No and reason – 2 marks Just ticked No – 0 marks	2
8	4C	a) 45°    b) 110°    c) 23°	All correct – 2 marks 2 correct – 1 mark	2
9	4B	290 minutes or 4 h 50 m	2 marks	2
10	4B	7 hours	1 mark	1
11	4A	a) 353.2 seconds b) Carl    c) 4.3 seconds	All correct – 2 marks 2 correct – 1 mark	2
12a	5C	7	1 mark	1
12b	5C	Any number between 111 and 120	1 mark	1
13	4A	368	Correct answer – 2 marks Correct method – 1 mark	2
14	4A	648	Correct answer – 2 marks Correct method – 1 mark	2
15	4A	£11.52	Correct answer – 2 marks Correct method – 1 mark	2
16	4A	£832	Correct answer – 2 marks Correct method – 1 mark	2
17	5C	a) x    d) + b) ÷    e) x, x c) –    f) +, ÷	All correct – 3 marks 4 – 5 correct – 2 marks Less than 4 – 0 marks	3
18	5C	a) 3    c) 3 b) 56    d) 5	All correct – 2 marks 2 or 3 correct – 1 mark	2
19	5B	2592000	Correct answer – 3 marks Correct method – 2 marks	3

Total- 39
-----------



Y5 Block 3 Assessments Sections A & B  
Guide to Levels

B3	3C	3B	3A	4C	4B	4A	5
0 – 12	13 – 19	20 – 27	28 – 35	36 – 43	44 – 51	52 – 59	60 – 69

Total Marks A + B = 69